

NOTE: TYPICAL C600/C605 ONE TONE - FIXED WINDOW - INSTALLATION INSTRUCTIONS

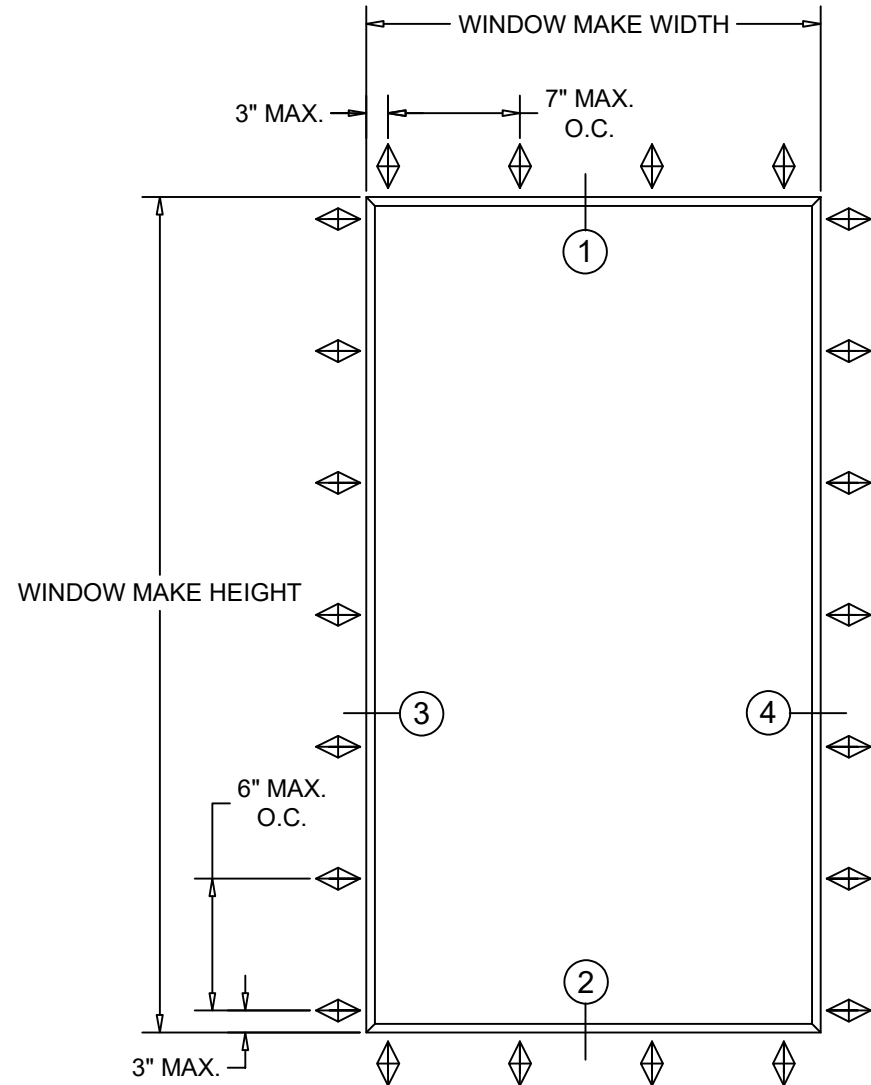

Maximum				
FW	FH	DLO-W	DLO-H	Pressure
60"	99"	56 3/4"	95 3/4"	± 100 PSF

Mark A

1" Insulating Glass
Two lights 3/16" Tempered Glass
with 5/8" Spacer

1 3/8" Insulating Glass
Two lights 3/16" Tempered Glass
with 1" Spacer

Notes:

1. Installations depicted satisfy the requirements of the 8th Edition (2023) of the Florida Building Code for Wind Pressures and Overall Sizes shown.
2. As Tested Anchor spacings are shown on the Elevations.
3. Wood Framing are assumed to Southern Pine (G=0.55) or denser.
4. Metal stud frames are assumed to be a minimum 16 gauge 33 KSI Steel.
5. Concrete masonry (CMU) shall conform to ASTM C90.
6. Concrete shall be minimum $f_c = 3,000$ psi.
7. Wood Screws shall meet requirements of ANSI/ASME B18.6.1.
8. TEKS screws shall be ASTM A510 Grade 1018 or equivalent.
9. Hilti Kwik-Con + anchors as specified in NOA 21-0628.20
10. Maximum Frame Shim Space is 1/4" as shown. Shims shall be non-compressible load bearing type.
11. Exterior and Interior shall be sealed according to Shop Drawings.
12. Products shown are NOT Impact Resistant and require an approved protection device if used in windborne debris regions.
13. Not for use in High Velocity Hurricane Zone (HVHZ).
14. Sealing and flashing strategies and overall water infiltration performance of the installed product are by others and not addressed by this document.

C605
Bevel
Stop

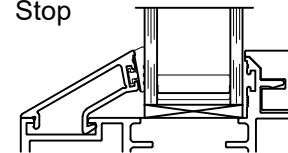

C600
SQUARE
Stop

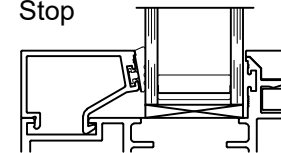

Standard 1" I.G.

C605
Bevel
Stop

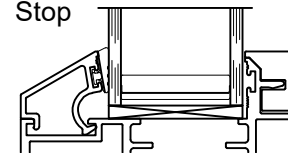

C600
SQUARE
Stop

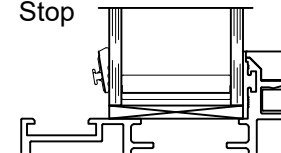

Optional 1 3/8" I.G.

Project Name:
**C600/C605 FIXED
One Tone
Installation Instructions**

GENERAL NOTES

QUAKER WINDOW PRODUCTS
WILL NOT BE RESPONSIBLE
FOR FIELD MEASUREMENT
QUANTITIES, & INSTALLATION
DESIGN. CONTRACTOR MUST
VERIFY ALL DIMENSIONS.

PHONE (573)-744-5211
FAX (573)-744-5586
COMMERCIAL
FAX (573)-744-5822
www.quakerwindows.com

Scale: NONE
Sheet #: 1 of 4

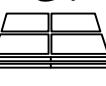

504 Highway 63 South
Freeburg, MO 65035
drafting@quakerwindows.com

Drawn By: Bud
Date: 07-10-2023

Tanya A. Dolby, P.E.
FL License No. 93536
Intertek - ATI
130 Derry Court, York, PA 17406
717-764-7700

NOTE: TYPICAL C600/C605 ONE TONE - FIXED WINDOW - NAIL FIN INSTALLATION

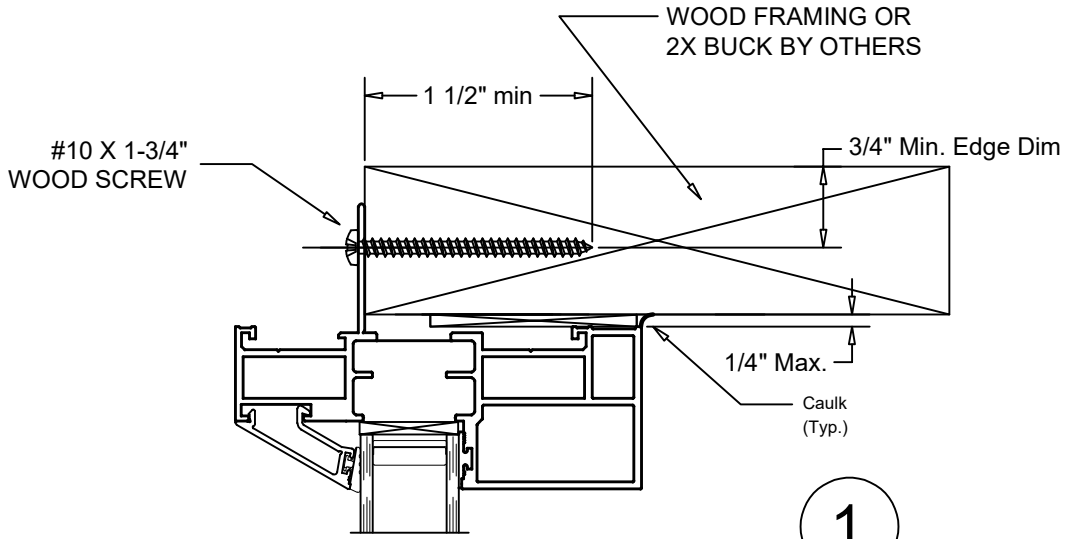

1

EXTERIOR

INTERIOR

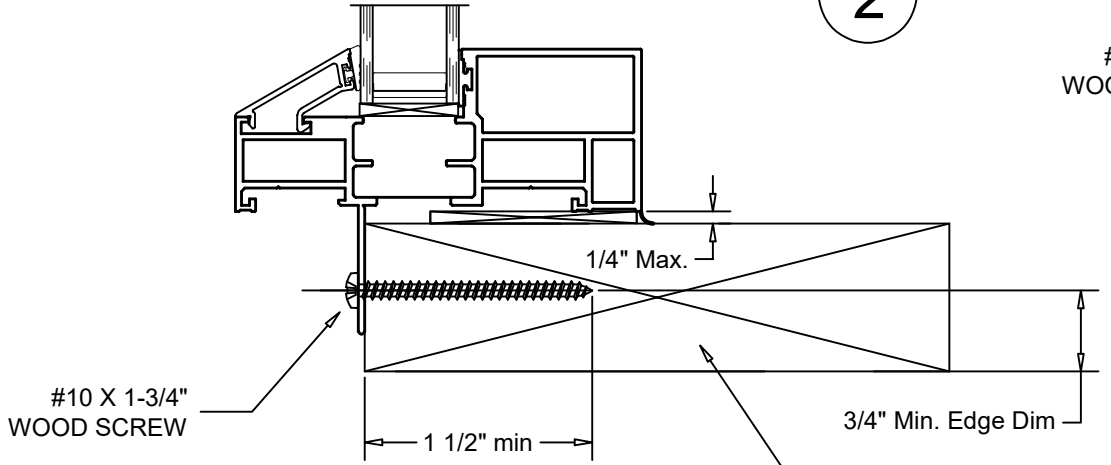

2

VERTICAL SECTION DETAIL

WOOD FRAMING INSTALLATION

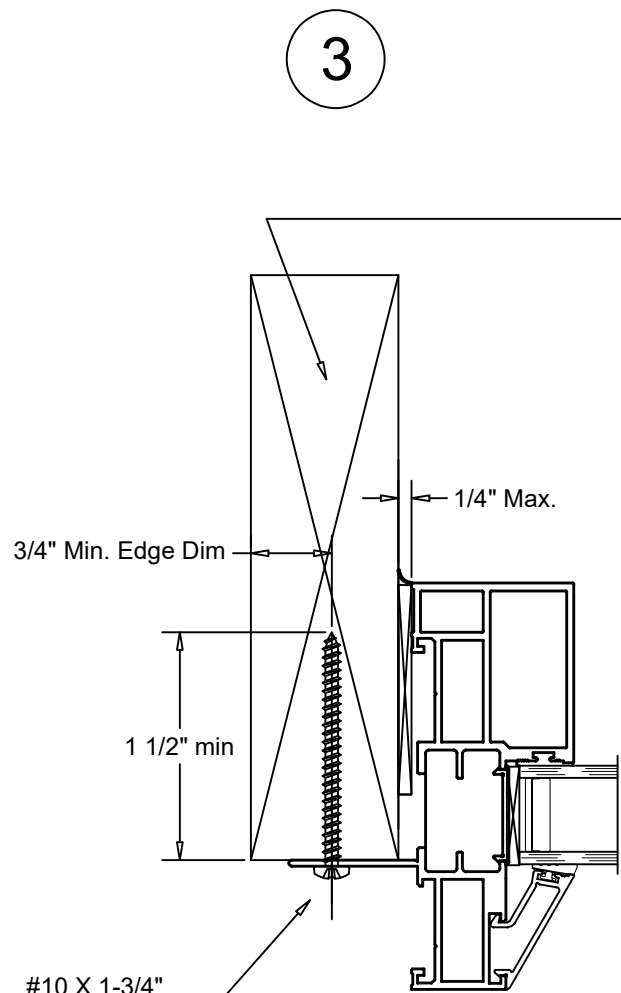

3

INTERIOR

EXTERIOR

HORIZONTAL SECTION DETAIL
WOOD FRAMING INSTALLATION

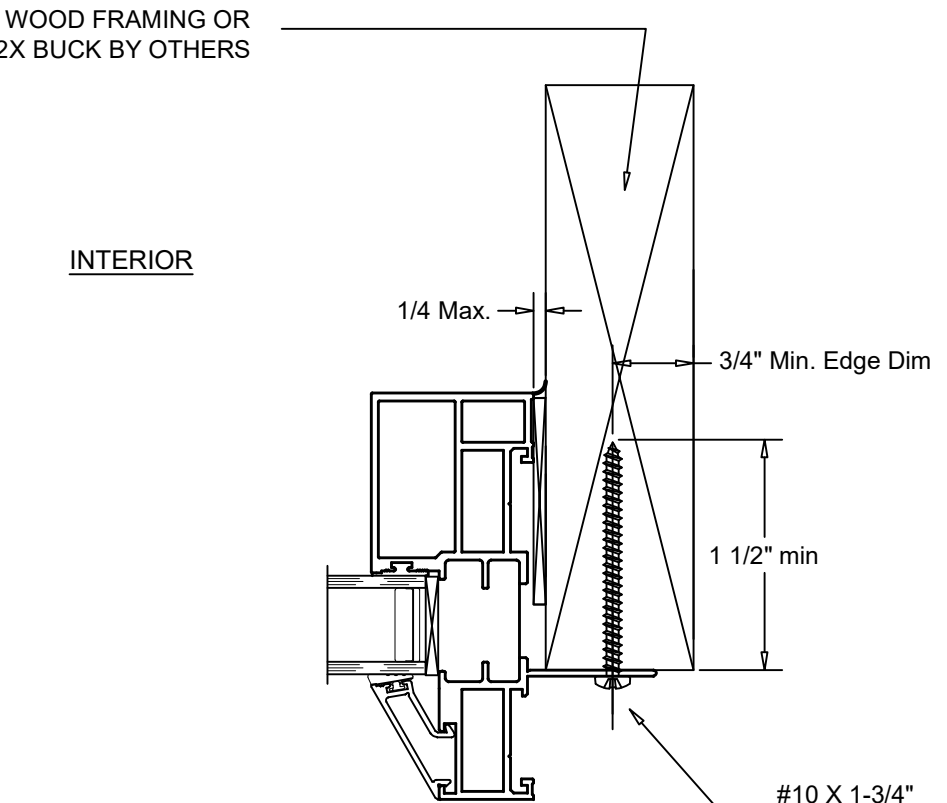

4

Project Name:
**C600/C605 FIXED
One Tone**
Installation Instructions

GENERAL NOTES

QUAKER WINDOW PRODUCTS
WILL NOT BE RESPONSIBLE
FOR FIELD MEASUREMENT,
QUANTITIES, & INSTALLATION
DESIGN. CONTRACTOR MUST
VERIFY ALL DIMENSIONS.

PHONE (573)-744-5211
FAX (573)-744-5586
COMMERCIAL
FAX (573)-744-5822
www.quakerwindows.com
Scale: NONE
Sheet #: 2 of 4
504 Highway 63 South
Freeburg, MO 65035
drafting@quakerwindows.com
Drawn By: Bud
Date: 07-10-2023

Tanya A. Dolby, P.E.
FL License No. 93536
Intertek - ATI
130 Derry Court, York, PA 17406
717-764-7700

NOTE: TYPICAL C600/C605 ONE TONE - FIXED WINDOW - NAIL FIN INSTALLATION

Tanya A. Dolby, P.E.
 FL License No. 93536
 Intertek - ATI
 130 Derry Court, York, PA 17406
 717-764-7700

INTERIOR

EXTERIOR

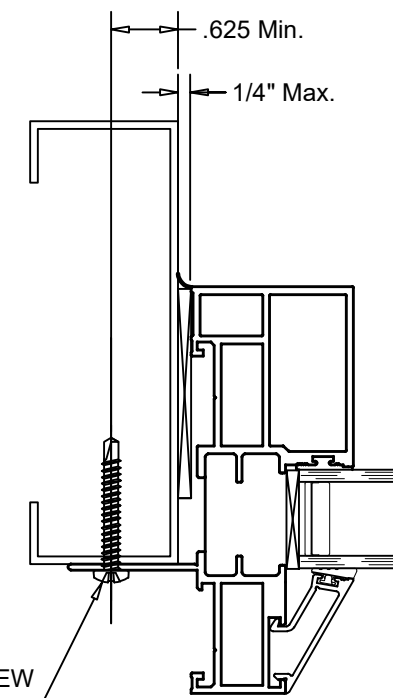

#10-16 TEKS SCREW
 MIN 3 FULL THREAD
 PENETRATION OF STEEL

3

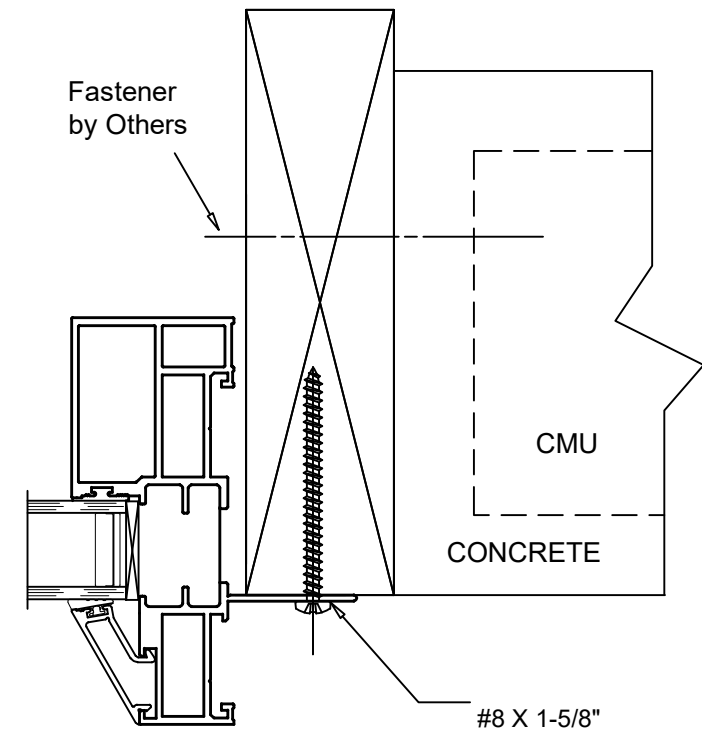

See Detail 4 on sheet 2 for
 wood anchorage

5

Project Name:
C600/C605 FIXED
One Tone
Installation Instructions

Description:
GENERAL NOTES

QUAKER WINDOW PRODUCTS
 WILL NOT BE RESPONSIBLE
 FOR FIELD MEASUREMENT
 QUANTITIES, & INSTALLATION
 DESIGN. CONTRACTOR MUST
 VERIFY ALL DIMENSIONS.

PHONE (573)-744-5211
 FAX (573)-744-5586
 COMMERCIAL
 FAX (573)-744-5822
 www.quakerwindows.com
 Scale: NONE
 Sheet #: 3 of 4

QUAKER
 commercial windows and doors

504 Highway 63 South
 Freeburg, MO 65035
 drafting@quakerwindows.com

Drawn By: Bud
 Date: 07-10-2023

NOTE: TYPICAL C600/C605 ONE TONE - FIXED WINDOW - NAIL FIN INSTALLATION

Bill of Materials				
NO.	Description	Part Number	Material	Manufacturer
1	Frame w/ Nail Fin	23015	Aluminum 6063-T6	Tower Extrusions
2	Beveled Glazing Bead	23982	Aluminum 6063-T6	Tower Extrusions
3	Square Glazing Bead	23114	Aluminum 6063-T6	Tower Extrusions
4	One Tone Fixed Frame w/ Nail Fin	23274	Aluminum 6063-T6	Tower Extrusions

Tanya A. Dolby, P.E.
 FL License No. 93536
 Intertek – ATI
 130 Derry Court, York, PA 17406
 717-764-7700

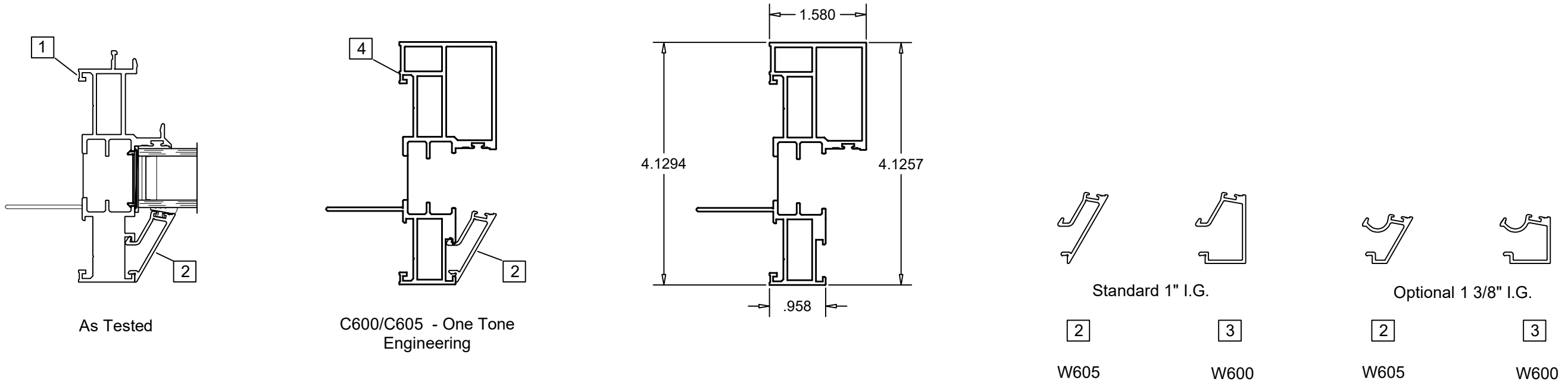

Project Name:
C600/C605 FIXED
 One Tone
 Installation Instructions

GENERAL NOTES

QUAKER WINDOW PRODUCTS
 WILL NOT BE RESPONSIBLE
 FOR FIELD MEASUREMENT
 QUANTITIES, & INSTALLATION
 DESIGN. CONTRACTOR MUST
 VERIFY ALL DIMENSIONS.

PHONE (573)-744-5211
 FAX (573)-744-5586
QUAKER
 COMMERCIAL
 CONSTRUCTION WINDOW AND DOOR
 FAX (573)-744-5822
 www.quakerwindows.com
 Scale: NONE
 504 Highway 63 South
 Freeburg, MO 65035
 drafting@quakerwindows.com
 Sheet #: 4 of 4
 Drawn By: Bud
 Date: 07-10-2023